



Polarized Media Electronic Air Cleaner

The Dynamic Polarized Media Electronic Air Cleaner installs directly into the 1" filter rack(s) in the existing heating and cooling system. Its electronically enhanced media combines elements of both electronic and media air cleaners. Particles are electrically charged (polarized) and then collected in the high efficiency media. Polarized sub-micron particles join with other particles and are collected on subsequent passes.



Actual unit may vary depending on size



FAST INSTALLATION

- No costly ductwork modifications required.
- Plugs directly into 110V wall outlet or can connect to R and C terminals on most furnace control boards.

EFFICIENT

- 97% efficient at .3 microns.
- Efficiency increases as the media fibers load.

REMOVES ODORS

- Patented activated-carbon center screen is effective in removing cigarette smoke, pollen, dust, odors, and other contaminants.

ECONOMICAL OPERATION

- Low static pressure drop lets blower run efficiently.
- Power consumption is about the same as a 40-watt light bulb.

EASY MAINTENANCE

- No washing of components required.
- The disposable fiber media pads require only a few minutes to change.
- Media pads are generally changed every 3 to 4 months, depending on household conditions such as the presence of pets and/or smokers.

SAFE, QUIET, DEPENDABLE OPERATION

- Runs on 24Volts that feeds a high voltage power supply producing 6500 volts of DC output current. Its extremely high internal impedance makes it very safe and virtually short-circuit proof.
- Does not produce ozone or arcing like other electronic air cleaners.
- Does not produce charged (ionized) particles that collect on clothes, walls and furnishings.

WARRANTY

- Backed by a Five (5) Year Limited Warranty.

Performance Data	
Electrical Input:	24 VAC
Powerhead Output Voltage:	6500V DC
Power Consumption:	2 Watts
Powerhead Volt/Amps Draw:	0.7VA
Maximum Face Velocity:	500 fpm
Ozone Generation:	None

Efficiency Comparison

Particle Size	Contaminant(s)	Dynamic Air Cleaner	Other 4-6" Pleated Filters
		Capture Efficiency	
3-10 microns	pollen, mold, dust mites, hairspray	99%	98%
1-3 microns	auto emissions, lead dust, large bacteria	98%	Not Effective
.3-1 micron	smoke (tobacco, cooking), small bacteria, fine dust, paint pigments	97%	Not Effective
<.3 micron	VOCs (odors, off gases including formaldehyde from carpets, furniture and cleaning products)	40%	Not Effective

Pressure Drop Data

Dynamic Polarized Media Electronic Air Cleaners operate at the equivalency of a MERV 14 air filter without the high pressure drop normally associated with high efficiency filters.

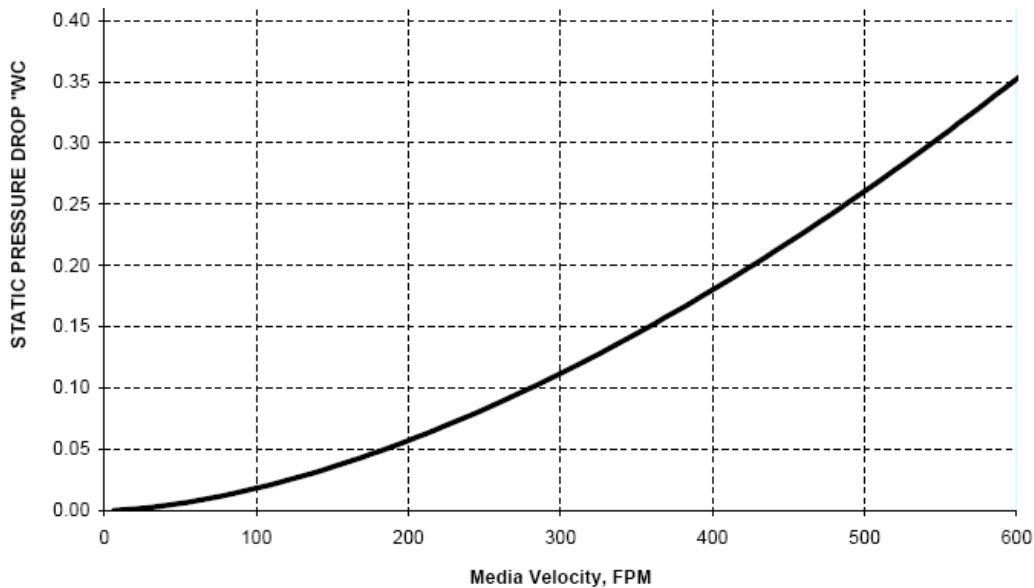

Dimension Data (standard sizes)

Dynamic Polarized Media Electronic Air Cleaners are available in the following standard sizes: 12X12, 12X20, 12X24, 12X30, 14X14, 14X20, 14X24, 14X25, 14X30, 15X20, 16X16, 16X20, 16X21, 16X24, 16X25, 16X30, 18X18, 18X20, 18X24, 18X25, 20X20, 20X22, 20X24, 20X25, 20X30, 24X24, 24X30, 25X25, 13-1/8X17-3/8, 16-1/2X21-5/8, 20X21-5/8, 21-1/2X23-1/4 and several return air grille sizes: 17-3/8X17-3/8, 17-3/8X23-3/8, 19-3/8X19-3/8, 19-3/8X29-3/8, 23-3/8X23-3/8. Custom sizes are also available.

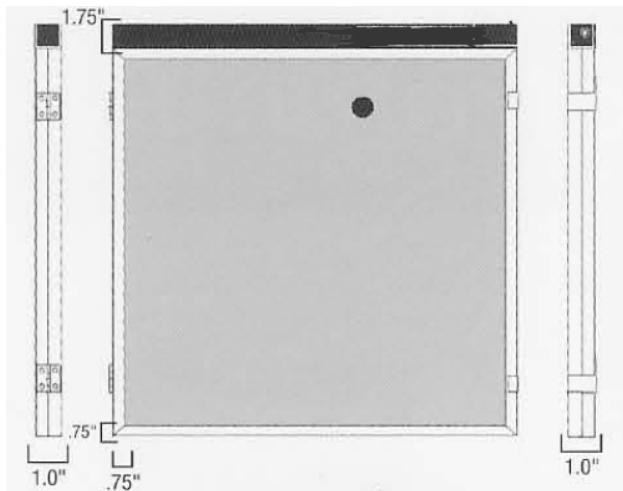

Note: Unit dimensions are ¼" under nominal filter sizes.

Retrofit Models

Dynamic Polarized Media Electronic Air Cleaners are also available in several models as a retrofit to slide into existing media or electronic air cleaner cabinets.

- | | |
|---------------------------------|--|
| 1RF1625C24 | replaces Honeywell 16x25
F50, F100, F150, F200, F300,
Trion 16x25 AirBear, HE 1400 |
| 1RF2025C24 | replaces Honeywell 20x25
F50, F100, F150, F200, F300,
Trion 20x25 AirBear, HE 2000 |
| 1SG21.525.5C24
1SG1728.25C24 | replaces SpaceGard 2200
replaces SpaceGard 2400 |
| 1AA2200C24
1AA2400C24 | replaces Aprilaire 2200
replaces Aprilaire 2400 |

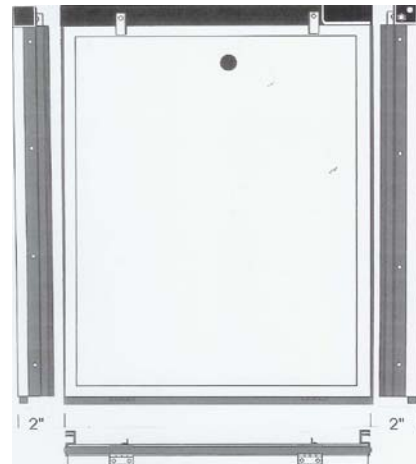

Operation

Each unit is shipped with a power supply cord that plugs into the air cleaner and wires directly to the "R" and "C" terminals located on most gas furnace integrated control boards. Refer to the Dynamic Polarized Media Electronic Air Cleaner Installation Instructions & Consumer Information for details.

An optional 110Volt step-down transformer allows the appliance to be plugged directly into any standard wall outlet.

Maintenance & Filter Media Pad Replacement

The only scheduled maintenance for the Dynamic Polarized Media Electronic Air Cleaners is periodic replacement of the Replacement Media Pads. This is typically done every 3 to 4 months.

WARNING: FAILURE TO CHANGE THE MEDIA PAD ON A REGULAR BASIS COULD REDUCE AIRFLOW AND CAUSE DAMAGE TO THE HEATING AND COOLING SYSTEM.

<u>Item</u>	<u>Description</u>
1	Replacement Media Pad
2	Powerhead (inside channel)
3	Power Cord
4	Electrode Insulator Button
5	Air Cleaner Latch
6	Power ON Light
7	Label "Unplug before Opening"
8	Power Input Jack
9	Label
10	Electrode
11	Model / Power Rating Label
12	Air Cleaner Size Label
13	Patent Label
14	Hinge
15	Screen
16	Frame
17	Spline

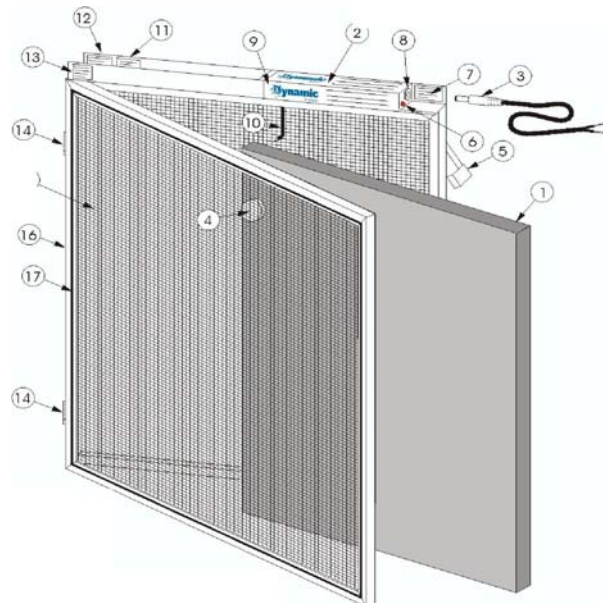

Dynamic Air Quality Solutions
P.O. Box 1258
Princeton, NJ 08542
Tel: (800) 578-7873
Fax (609) 924-8524
www.DynamicAQS.com

Specifications are subject to change without notice.
Dynamic and Dynamic Air Quality Solutions are registered
trademarks of Environmental Dynamics Group,
PO Box 1258, Princeton, NJ 08542

©2006 EDG

FORM NO. DYN-440 (10/06)